

Filter pressure regulator, Series AS3-FRE

- G 3/8 G 1/2
- filter porosity 40 µm
- lockable
- for padlocks
- suitable for ATEX

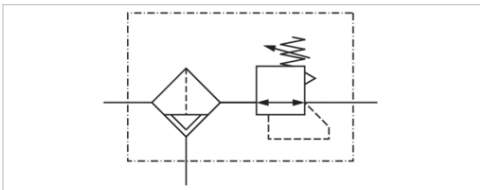

Version	1-in-1, Can be assembled into blocks
Parts	Filter pressure regulator
Mounting orientation	vertical
Certificates	suitable for ATEX
Working pressure min./max.	See table below
Ambient temperature min./max.	-10 ... 50 °C
Medium temperature min./max.	-10 ... 50 °C
Medium	Compressed air Neutral gases
Nominal flow Qn	5100 l/min
Regulator type	Diaphragm-type pressure regulator
Regulator function	with relieving air exhaust
Adjustment range min./max.	0,5 ... 10 bar
Pressure supply	single
Filter reservoir volume	49 cm ³
Filter element	exchangeable
Condensate drain	See table below
Weight	See table below

Technical data

Part No.	Port	Flow	Working pressure min./max.
		Qn	
R412007218	G 3/8	5100 l/min	1,5 ... 16 bar
R412007219	G 3/8	5100 l/min	1,5 ... 16 bar
R412007220	G 3/8	5100 l/min	0 ... 16 bar
R412007221	G 1/2	5100 l/min	1,5 ... 16 bar
R412007222	G 1/2	5100 l/min	1,5 ... 16 bar
R412007223	G 1/2	5100 l/min	0 ... 16 bar

Part No.	Condensate drain	Weight
R412007218	semi-automatic, open without pressure	0,586 kg
R412007219	fully automatic, open without pressure	0,635 kg
R412007220	fully automatic, closed without pressure	0,635 kg
R412007221	semi-automatic, open without pressure	0,586 kg
R412007222	fully automatic, open without pressure	0,635 kg
R412007223	fully automatic, closed without pressure	0,635 kg

Nominal flow Qn with secondary pressure p₂ = 6 bar at Δp = 1 bar

Order pressure gauge separately, Suitable for use in Ex zones 1, 2, 21, 22

Technical information

The pressure dew point must be at least 15 °C under ambient and medium temperature and may not exceed 3 °C .

Note: Polycarbonate reservoirs are susceptible to solvents, supplementary information can be found at "Customer information".

Suitable for use in Ex zones 1, 2, 21, 22

A change in the flow direction (from air supply on the left to air supply on the right) occurs by rotating installation by 180° about the vertical axis. Please see the operating instructions for further details.

Also suitable for separation of fluid oil or water due to the design.

Max. residual oil content acc. to ISO 8573-1 at the outlet 10 mg/m³

Technical information

Material	
Housing	Polyamide
Front plate	Acrylonitrile butadiene styrene
Seals	Acrylonitrile butadiene rubber
Threaded bushing	Die cast zinc
Reservoir	Polycarbonate
Protective guard	Polyamide
Filter insert	Polyethylene

Dimensions

Dimensions

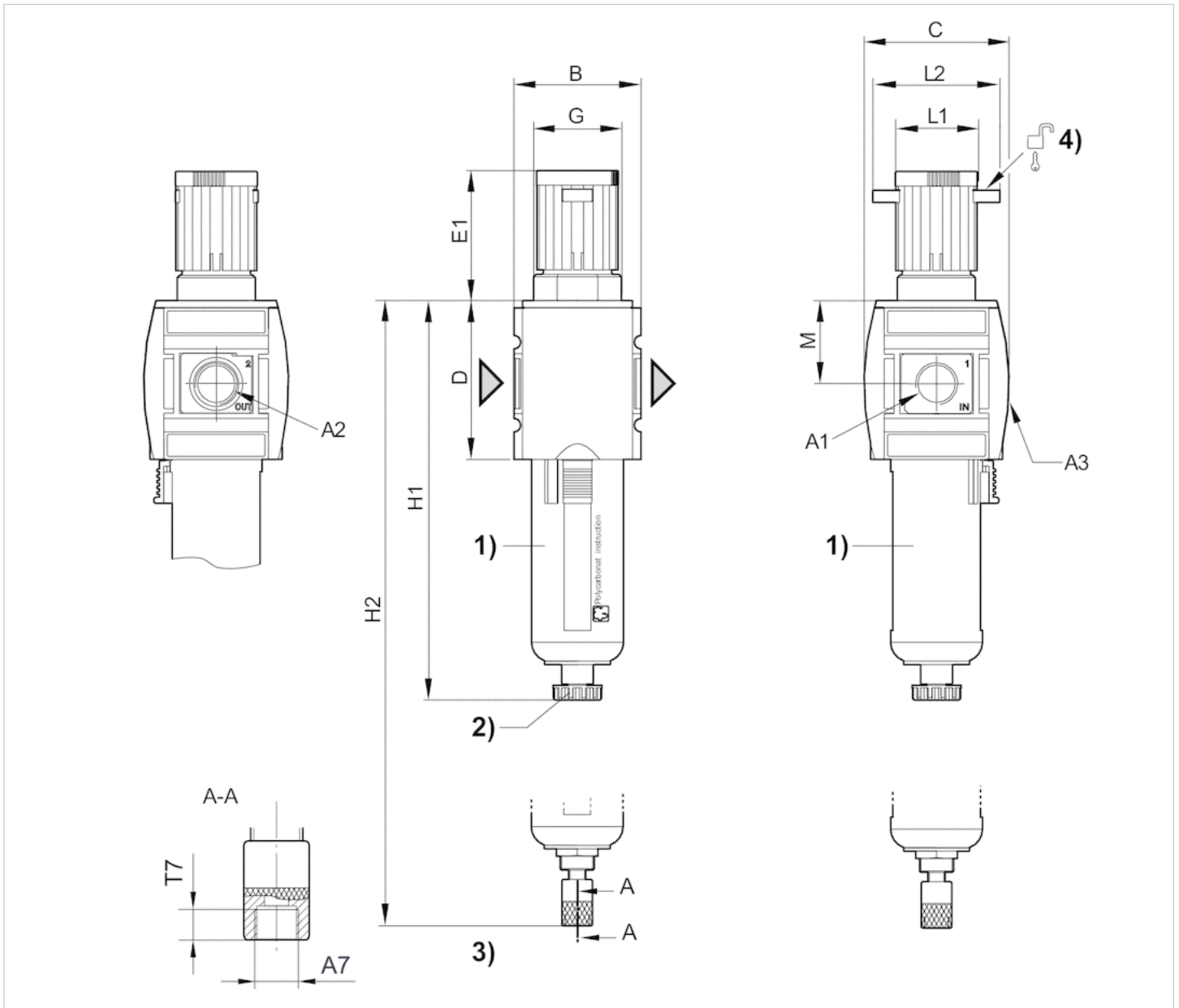

- A1 = input
- A2 = output
- A3 = pressure gauge connection
- A7 = condensate drain
- 1) Plastic reservoir and protective guard with window
- 2) Semi-automatic condensate drain
- 3) Fully automatic condensate drain
- 4) Mounting option for padlocks; max. shackle Ø 8

Dimensions in mm

A1	A2	A3	A7	B	C	D	E1	G	H1	H2	L1	L2	T7	M
G 3/8	G 3/8	G 1/4	G 1/8	63	74	80	63.5	M42x1,5	189.5	206	41	60	8.5	42.5
G 1/2	G 1/2	G 1/4	G 1/8	63	74	80	63.5	M42x1,5	189.5	206	41	60	8.5	42.5

Diagrams

Pressure characteristics curve

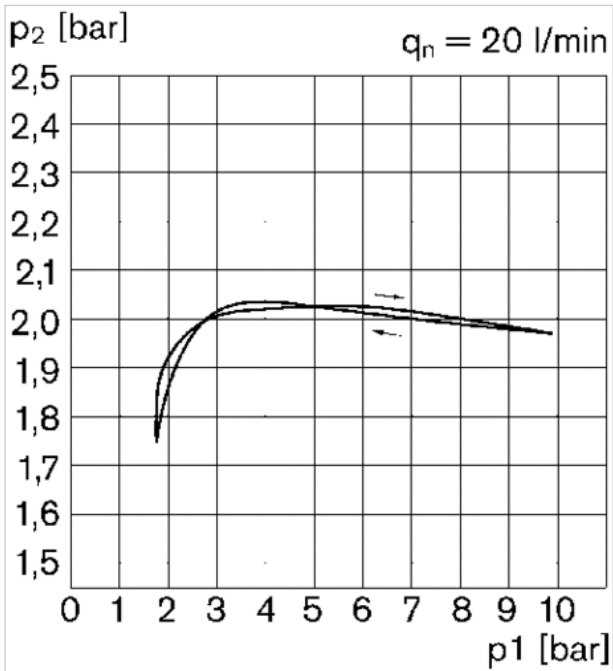

p_1 = Working pressure p_2 = Secondary pressure q_n = Nominal flow

Flow rate characteristic (p_2 : 0.5 - 8 bar)

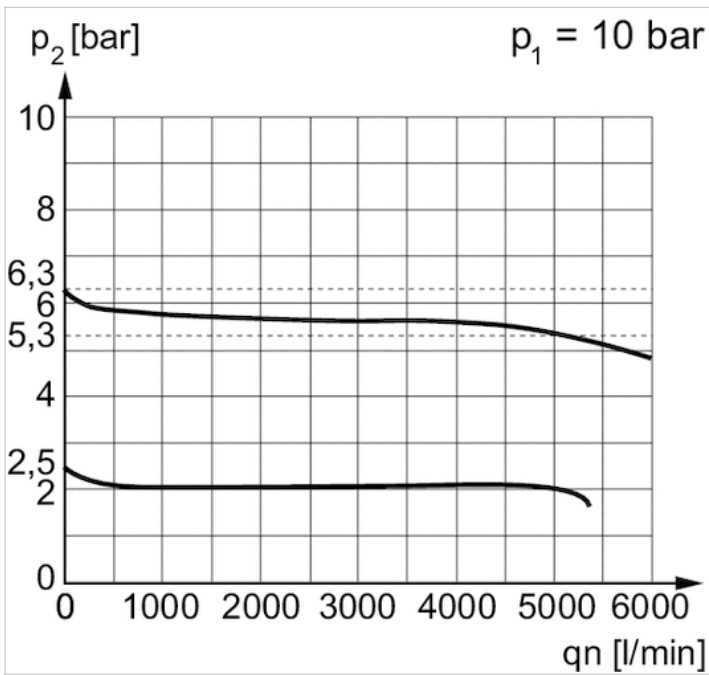

p_1 = Working pressure p_2 = Secondary pressure q_n = Nominal flow